



### PRODUCT OVERVIEW

MWOCP74-3000-A-RM is a highly efficient, 80PLUS® certified Titanium 3,030-watt, OCP compliant front-end power module featuring a 12Vdc main output and a 12Vdc, 2.5A standby output. This power module is compatible with Murata OCP Open Rack compliant shelves, such as [MWOCEs-211-x](#) or [MWOCEs-192-x](#) where up six (6) power modules can be installed delivering up to 15kW, N+1 rack level power. MWOCP74-3000-A-RM is hot pluggable, accurately current shares, provides status LEDs, logic signals and a comprehensive PMBus™ communications bus and is ideal for any application requiring highly reliable, distributed power architectures.

### ORDERING GUIDE

Part Number	Output Power		Output Voltage (Vdc)		Airflow
	90-180Vac	180-300Vac & 192-400Vdc	Main	Standby	
MWOCP74-3000-A-RM	1830W	3030W	12.3Vdc	12.2Vdc	Front to Back

### FEATURES

- 3,030W output power
- Meets 80PLUS® Titanium efficiency (96% efficiency at 50% load)
- 12.3V main output & 12.2V standby output
- 1U height 73.5 x 550 x 40mm (2.89" x 21.65" x 1.57")
- 30.4W/cubic inch power density
- N+1 redundancy capable
- Hot pluggable
- Active current sharing on 12V main output, ORing FET isolation
- Overvoltage, overcurrent, over temperature protection and reporting
- Internal cooling FAN (variable speed)
- PMBus™ / I<sup>2</sup>C interface with dual LED status indicators
- RoHS compliant
- 2-year warranty

### INPUT CHARACTERISTICS

Parameter	Conditions	Min	Typ.	Max	Units
Input Voltage Operating Range	AC	90	100/115/230/277	300	Vac
	DC	192	240/380	400	Vdc
Turn-on Voltage	AC (Ramp-up)	80		87	Vac
	DC (Ramp-up)	182		190	Vdc
Turn-off Voltage	AC (Ramp-down)	73		85	Vac
	DC (Ramp-down)	172		180	Vdc
Maximum Input Current	Vin; 100Vac; 1830W			21	Arms
Inrush Current	Cold Start; <200ms			50	Apk
Power Factor	230 Vac; FL		0.99		WVA
Efficiency (Excluding Fan Load)	230Vac; 10% FL	90	91.5		%
	230Vac; 20% FL	94	94.5		
	230Vac; 50% FL	96	96.2		
	230Vac; 100% FL	91	94.0		

### OUTPUT VOLTAGE CHARACTERISTICS

Output	Parameter	Conditions	Min	Nom	Max	Units	
12V main	Nominal output voltage			12.3		V	
	Output set point accuracy	50% load, Ta=25°C	-0.5		0.5	%	
	Line and load regulation		-5.0		5.0	%	
	Ripple voltage & noise <sup>1</sup>	20MHz bandwidth			160	mVpp	
	Output current	High line		0		244	A
		Low line		0		146.5	
	Overload characteristics	Refer to Fig.1a & 1b					
	Load capacitance			0		30,000	uF
12VSB	Nominal output voltage			12.2		V	
	Output set point accuracy	50% load, Ta=25°C	-0.5		0.5	%	
	Line and load regulation		-5.0		5.0	%	
	Ripple voltage & noise <sup>1</sup>	20MHz bandwidth			150	mVpp	
	Output current			0		2.5	A
	Load capacitance			0		3,000	uF

<sup>1</sup>Ripple and noise are measured with 0.1uF of ceramic capacitance and 10uF of tantalum capacitance on each of the power supply outputs. A short coaxial cable with 50Ω scope termination is used



For full details go to:  
[www.murata-ps.com/rohs](http://www.murata-ps.com/rohs)



OUTPUT CHARACTERISTICS					
Parameter	Conditions	Min	Typ.	Max	Units
Startup Time	From application of the AC source to 90% of the 12VSB			3	sec
Transient Response	12V main, 50% load step within range of 5% to 100%, 1A/us di/dt, recovery within 500us	-600		600	mVpp
	12VSB, 50% load step within range of 5% to 100%, 1A/us di/dt, recovery within 500us	-600		600	
12V main output current sharing accuracy (module to module deviation) up to 6 modules in parallel	Percentage of total host system load current / number sharing units	-5		5	%
Hot Swap Transients	All outputs remain within regulation band	-5		5	
Holdup Time	100% load	12			ms

ENVIRONMENTAL CHARACTERISTICS					
Parameter	Conditions	Min	Nom	Max	Units
Storage temperature range		-40		70	°C
Operating temperature range	Altitude < 1,880m (5,905 ft)	0		50	°C
	Altitude < 3,000m (16,404 ft)	0		40	
Operating humidity	Non-condensing	5		90	%
Storage humidity		5		95	%
System back pressure tolerance (Target: Module P-Q curves to be provided)		0.5/125			in-H <sub>2</sub> O/Pa
MTBF (Target)	Per Telcordia SR-332 issue 3 M1C3 @ 40°C	300k			hrs
Shock	30G non-operating				
Operating vibration	Sine sweep:5-150Hz, 2G				
	Random vibration, 5-500Hz, 1.11G				
Safety approval	CAN/CSA C22.2 No.60950-1-07, Am.1:2011, Am2:2014 UL60950-1-2014, 2 <sup>nd</sup> Ed. IEC60950-1-2005 2 <sup>nd</sup> Ed. +A1:2009+A2:2013 EN60950-1:2006 +A11+A1+A12+A2 CQC GB4943.1-2011				
Input fuse	Dual internal fuses 25A/500V fast blow on the AC line and neutral input connections				
Weight	5.3lbs (2.4kg)				

PROTECTION CHARACTERISTICS						
Output	Parameter	Conditions	Min	Nom	Max	Units
12V main	Over temperature (intake)	Auto restart	50		60	°C
	Overvoltage	Latching, recycling AC source or toggle PS_ON to reset	13		14	V
	Overcurrent >180Vac	Latching	268		317	A
	Overcurrent <180Vac	Latching	161		190	A
12VSB	Overvoltage	Latching, recycling AC source to reset	13		14	V
	Overcurrent	Hiccup	3.5		4.5	A

ISOLATION CHARACTERISTICS					
Parameter	Conditions	Min	Nom	Max	Units
Insulation safety rating / test voltage	Input to output - Reinforced	3,000			Vrms
	Input to chassis - Basic	1,500			
Isolation	Output to chassis	50			Vdc

EMISSION AND IMMUNITY		
Characteristics	Standard	Criteria
Input current harmonics	IEC/EN 61000-3-2	Complies
Voltage fluctuation and flicker	IEC/EN 61000-3-3	Complies
Conducted emission	FCC47 CFR part15/CISPR 22/ EN55022	Class A with 6dB margin
ESD immunity	IEC/EN 61000-4-2	Level 4 criteria A
Radiated field immunity	IEC/EN 61000-4-3	Level 3 criteria B
Electrical fast transient/burst immunity	IEC/EN 61000-4-4	Level 3 criteria B
Surge immunity	IEC/EN 61000-4-5	Level 4 criteria A
RF conducted immunity	IEC/EN 61000-4-6	Level 3 criteria A
Magnetic field immunity	IEC/EN 61000-4-8	3A/m criteria B
Voltage dips, interruptions	IEC/EN 61000-4-11	230V <sub>in</sub> , 100% load, phase 0°, dip 100% duration 10ms (A) 230V <sub>in</sub> , 50% load, phase 0°, dip 100% duration 20ms (12V <sub>main</sub> :B, 12V <sub>SB</sub> :A) 230V <sub>in</sub> , 100% load, phase 0°, dip 100% duration >20ms (B)

RELATED PRODUCTS		
Model	Function	Description
MWOC193-xx-A-Rxx	OCP Power Shelf	19" x 2.5RU up to 18kW OCP Compliant Power Shelf comprised of the Power Shelf, 6PSUs, 1 RMU with optional Automatic Transfer Switches and Power Assists Modules (PAU)
MWOC211-xx-A-Rxx	OCP Power Shelf	21" x 10U up to 18kW OCP Compliant Power Shelf comprised of the Power Shelf, 6PSUs and 1 RMU.
MWOC-ATS-x	ATS	Automatic Transfer Switch
MWOC-PAU-xx	PAU	Power Assists Unit [Lithium ion battery for peak shaving and demand response]
MWOC-RMU-x	RMU	Remote Management Unit provides communication to a host for monitoring and control of the Shelf

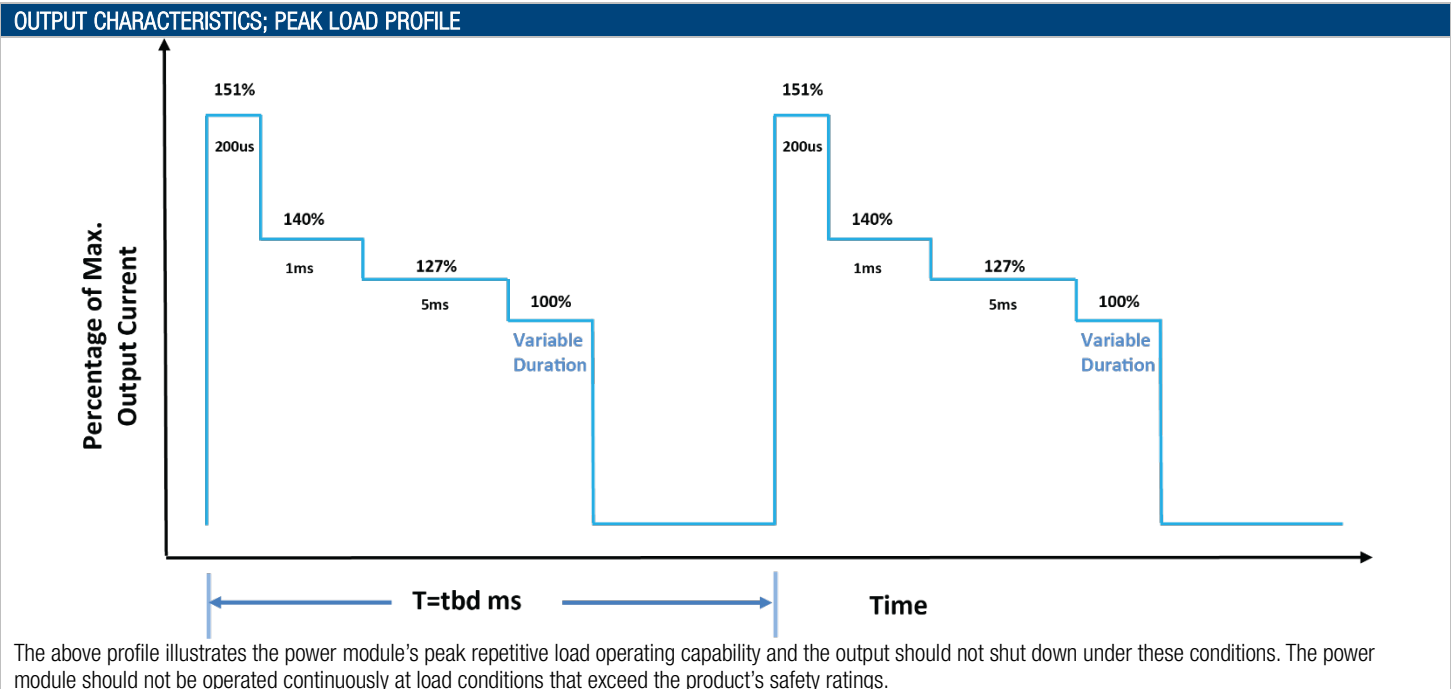

## STATUS AND CONTROL SIGNALS

Signal Name	Description	Interface Details
<a href="#">12V_main_REMOTE_SENSE</a> & <a href="#">12V_main_REMOTE_SENSE_RETURN</a>	The remote sense signals are intended can be connected at point of load. The power module senses this remote output voltage and can compensate for up to 0.25Vdc of voltage drop due to resistive losses caused by the load current and associated connection. For best performance, the remote sense lines should be routed away from noise sourced and be twisted together if using a harness.	
<a href="#">VIN_GOOD</a>	This active high signal Indicates incoming source voltage (AC or DC) is valid	Link to <a href="#">interface details</a>
<a href="#">PWOK</a>	Power Okay signal Indicates all outputs are valid and without faults	Link to <a href="#">interface details</a>
<a href="#">SMBALERT_L</a>	This signal asserts (low state) to indicate to the host/system that a fault condition has been detected within the power module. This signal asserts coincident with the setting of any supported PMBus™ status_x register fault bit flags. Refer to <a href="#">ACAN-109</a> for details	Link to <a href="#">interface details</a>
<a href="#">SCL, SDA</a>	Clock (SCL) and data (SDA) serial digital lines, compatible with PMBus™ Power Systems Management Protocol Part 1 – General Requirements Rev 1.2 and includes 45p internal capacitance.	Link to <a href="#">interface details</a>
<a href="#">SIGNAL_RETURN</a>	Signal return is the reference point for all signals and is separate from the main output return.	signal ground must be externally connected to 12VSB_RETURN (at system side)
<a href="#">I_SHARE</a>	This signal is connected between sharing units forming a current share bus. It is an input and/or an output (bi-directional analog bus) as the voltage on the line controls the current share between sharing units. A power module will respond to a change in this voltage and a power supply can also change the voltage depending on the load drawn from it. On a single unit, the voltage on the pin (and the common ISHARE bus) would read approximately 8VDC at 100% load (single power module capability). For two identical units sharing this same 100% load this would read approximately 4VDC for perfect current sharing (i.e. 50% module load capability per power module).	
<a href="#">12VSB_RETURN</a>	Standby output return is an independent return for the signal reference and is internally connected to VSB Return and Main Output Return.	signal ground must be externally connected to 12VSB_RETURN (at system side)
<a href="#">PSKILL</a>	This signal is used for internal power module power processing to ensure glitch free operation during power module insertion or extraction into/from host/system and is internally pulled up. This signal must be connected to signal return at system side and is provided on shortest pin (last to make, first to break contact). The main 12V output is enabled upon detecting the low state and disabled when a low state is no longer detected.	Link to <a href="#">interface details</a>
<a href="#">PS_ON_L</a>	Provides remote on/off control of the main 12V output. This signal is internally pulled up. The main output is turned on when this signal is externally connected to signal return and off when not connected to signal return.	Link to <a href="#">interface details</a>
<a href="#">PS_A2</a> <a href="#">PS_A1</a> <a href="#">PS_A0</a>	PMBus™ address selection for power module; Short either pins to signal return set the address line to logic Low to set hardware slave address. Open or pull up externally set the pin to logic High. PS_A2 is the most significant bit. Refer to <a href="#">ACAN-109</a> for details.	Link to <a href="#">interface details</a>
<a href="#">PRESENT</a>	The signal is used to detect the presence (installation) of a power module by the host system.	Link to <a href="#">interface details</a>

## STATUS & CONTROL SIGNAL INTERFACE DETAILS

Signal name	PSU Internal Pull up / down	Input / Output to PSU	3V3 Logic	Logic High V (min)	Logic Low V (max)	I_source mA (max)	I_sink mA (max)
VIN_GOOD	Open drain, no internal pull up	Output	YES		0.4		10
PWOK	Open collector, no internal pull up	Output	YES		0.4		4
SMBALERT_L	Open collector, no internal pull up	Output	YES		0.4		4
SCL & SDA	12.1k pull to 3V3 with isolated diode	I/O	YES	2.1	1.1	4	4
PSKILL	10k pull up to 3V3 internally	Input	YES	2.1	0.66	0.33 #	
PS_ON_L	4.75k pull up to 3V3 internally	Input	YES	2.1	0.66	0.69 #	
PS_A2, PS_A1 & PS_A0	10k pull up to 3V3 internally	Input	YES	2.1	1.1	0.33 #	
PRESENT	100R pull down to SIGNAL_RETURN	Output					

Link back to [STATUS AND CONTROL SIGNALS MAIN TABLE](#)

## INPUT AND SIGNAL INTERFACE CONNECTOR

The MWOCP74-3000-A-RM is provided with two sets of connections:

- A card edge consisting of “gold fingers” that provisions the incoming source (AC or HVDC) plus the “Standby” supply and signal I/O
- RADSOK® terminals to provision the 12V Main DC output

Input & Signal Interface Connector, Power Module Side (gold finger/card edge): [Link to Pin Map](#)

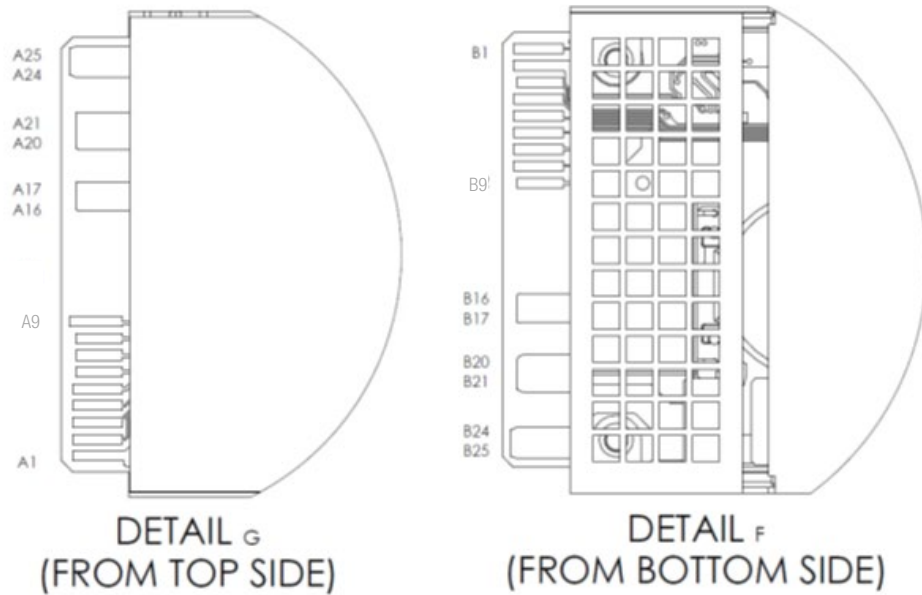

Input & Signal Interface Connector, Mating side: AMPHENOL/FCI PN FCI 10035388-110LF

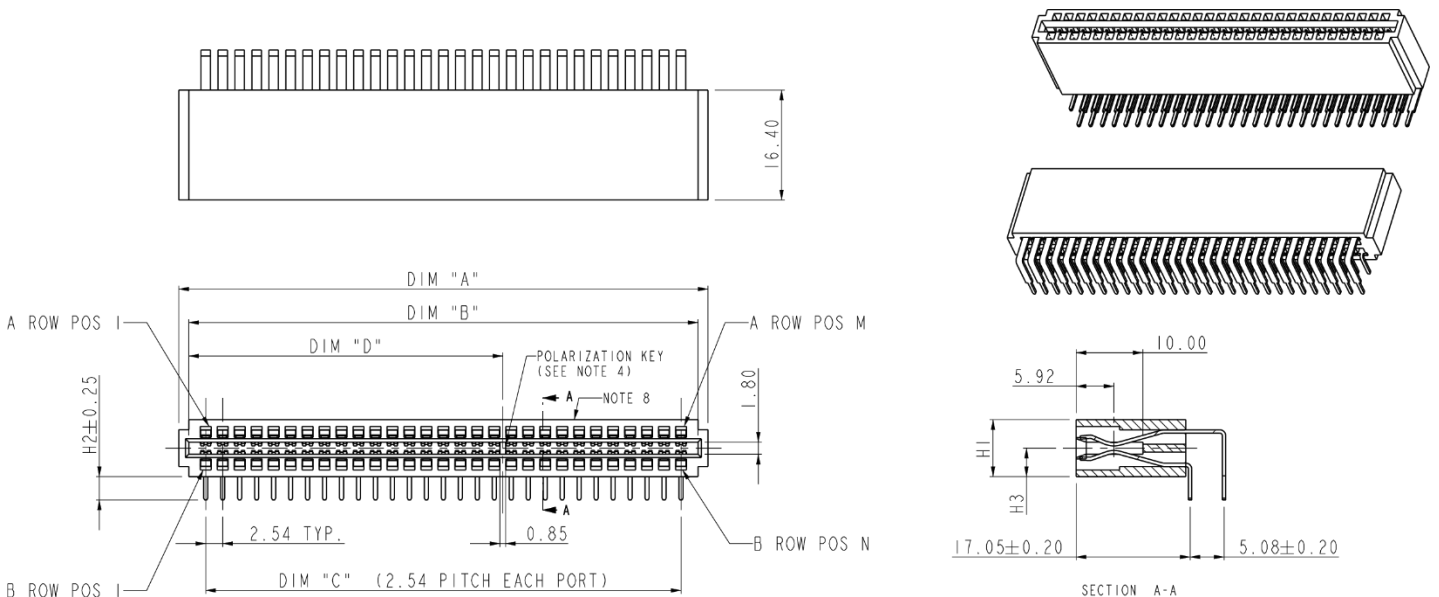

## INPUT AND SIGNAL INTERFACE CONNECTOR PIN MAP

Pin Location	Signal Name	Pin Location	Signal Name
A1	12VSB (12V standby output)	B1	I_SHARE
A2	12V main_REMOTE_SENSE_RETURN	B2	12VSB_RETURN (12V standby output return)
A3	12V main_REMOTE_SENSE	B3	PSKILL
A4	VIN_GOOD	B4	PS_ON_L
A5	PWOK	B5	No End User Connection, Reserved for future use <sup>1</sup>
A6	SMBALERT_L	B6	PS_A2
A7	SCL	B7	PS_A1
A8	SDA	B8	PS_A0
A9	SIGNAL_RETURN	B9	PRESENT
A16, A17	<b>NEUTRAL</b> Incoming Neutral/L2 or HVDC connection; Dual fusing allows for phase connection of suitable voltage rating	B16, B17	<b>NEUTRAL</b> Incoming Neutral/L2 or HVDC connection; Dual fusing allows for phase connection of suitable voltage rating
A18, A19	No User Connection, these positions are required for safety spacing <sup>1</sup>	B18, B19	No User Connection, these positions are required for safety spacing <sup>1</sup>
A20, A21	<b>Line/L1/HVDC</b> Incoming line/phase or HVDC connection; Dual fusing allows for phase connection of suitable voltage rating	B20, B21	<b>Line/L1/HVDC</b> Incoming line/phase or HVDC connection; Dual fusing allows for phase connection of suitable voltage rating
A22, A23	No User Connection, these positions are required for safety spacing <sup>1</sup>	B22, B23	No User Connection, these positions are required for safety spacing <sup>1</sup>
A24, A25	<b>PE</b> Protective earth; connects to enclosure/chassis	B24, B25	<b>PE</b> Protective earth; connects to enclosure/chassis

<sup>1</sup> Leave mating connector pin locations unterminated (dry)

## MAIN 12V OUTPUT CONNECTIONS

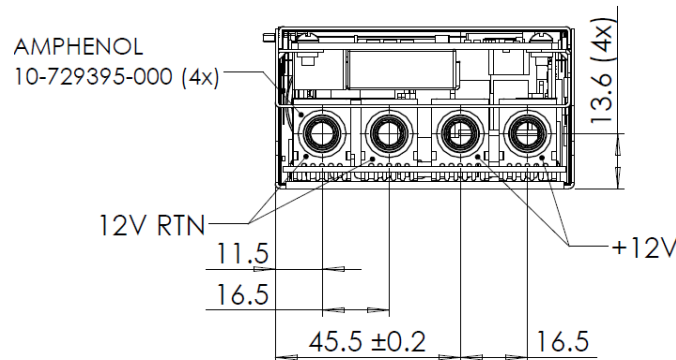

**MECHANICAL DIMENSIONS**

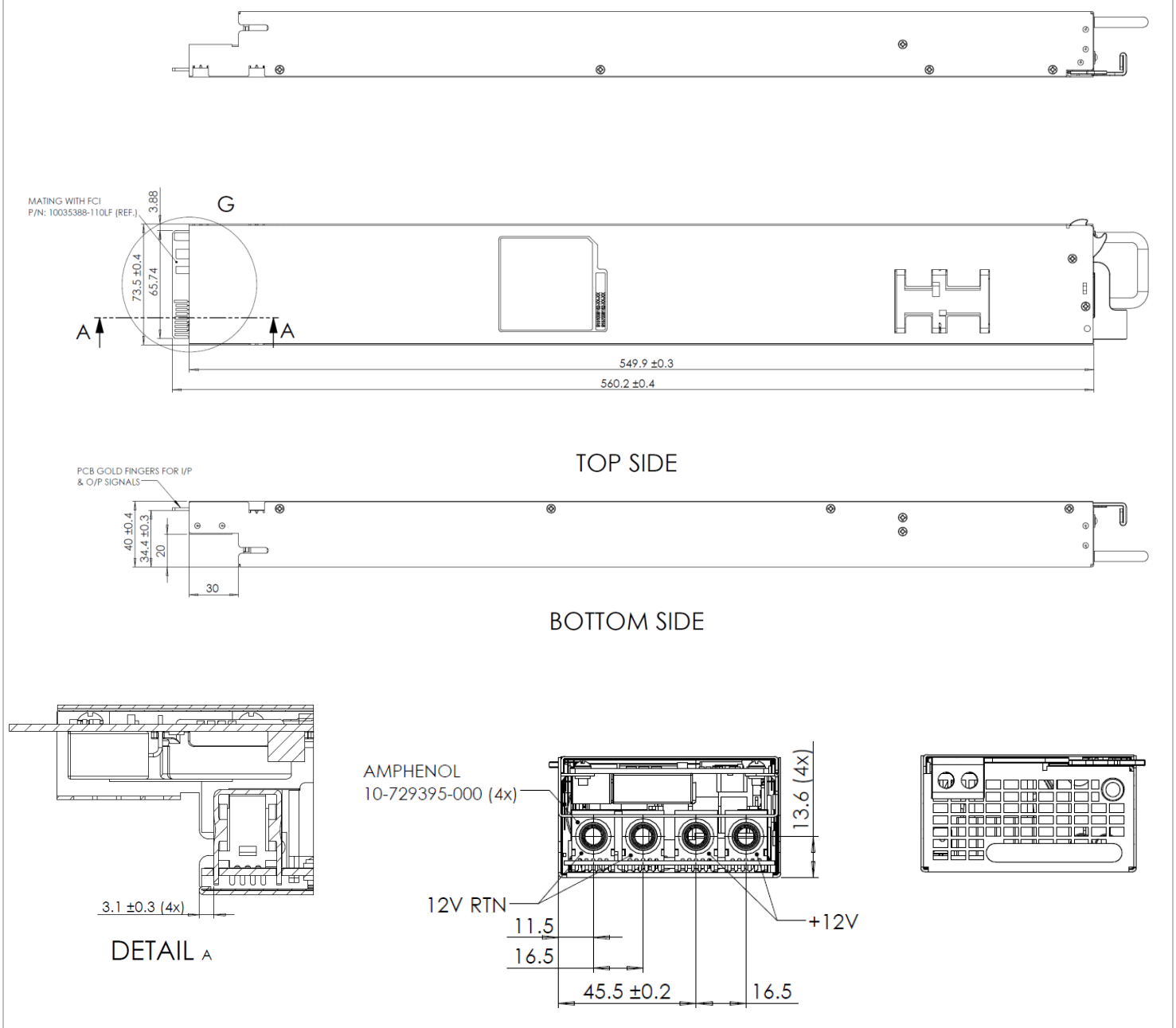

**APPLICATION NOTES**

Document Number	Description	Link
ACAN-109	MWOCP74-3000-A-RM PMBus™ Protocol	<a href="https://power.murata.com/datasheet/?data/apnotes/acan-109.pdf">https://power.murata.com/datasheet/?data/apnotes/acan-109.pdf</a>

Murata Power Solutions, Inc.  
 129 Flanders Rd. Westborough, Ma 01581, USA  
 ISO 9001 and 14001 REGISTERED

**This product is subject to the following operating requirements and the Life and Safety Critical Application Sales Policy:**

Refer to: <https://www.murata-ps.com/requirements/>

Murata Power Solutions, Inc. makes no representation that the use of its products in the circuits described herein, or the use of other technical information contained herein, will not infringe upon existing or future patent rights. The descriptions contained herein do not imply the granting of licenses to make, use, or sell equipment constructed in accordance therewith. Specifications are subject to change without notice.

© 2019 Murata Power Solutions, Inc.